

TOOLS

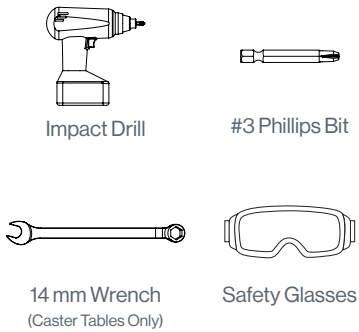

PARTS & HARDWARE LIST

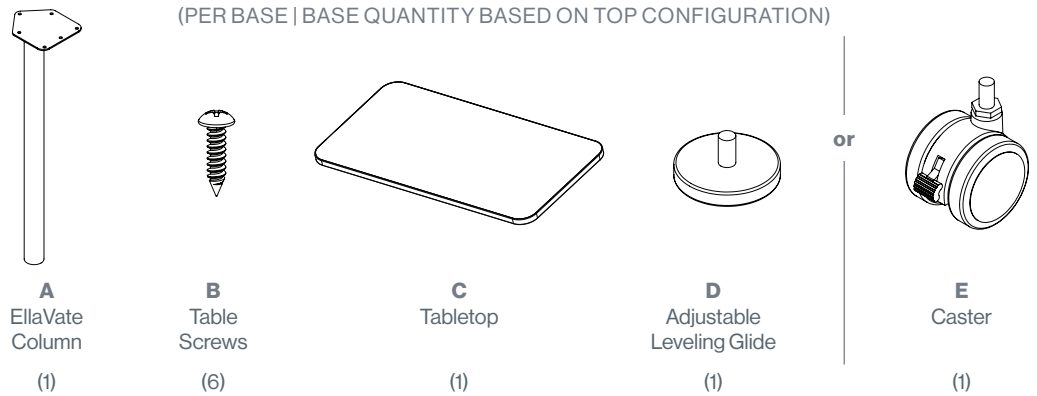

D or E 

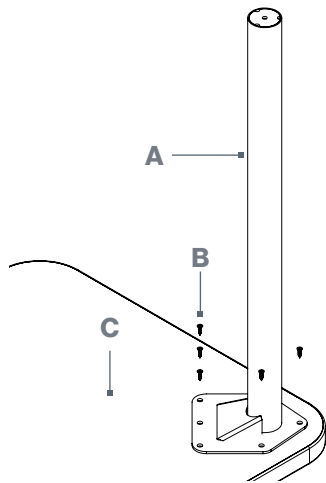
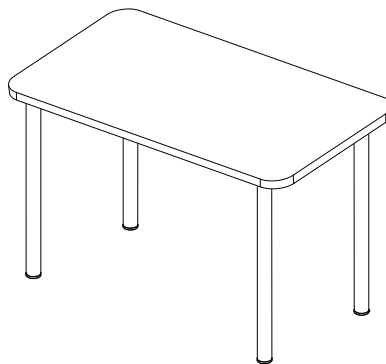

TABLE ASSEMBLY

1. Lay the tabletop (C) upside down on a piece of cardboard or carpeted surface.
2. Align the EllaVate Column Mounting Plate (A) with predrilled holes in the table surface (C).
3. Attach to the surface using (6) Table Screws (B).
4. Install Adjustable Leveling Glide (ELV-FH) (D) or Install Locking Caster (E) using 14MM wrench (ELV-FH-C).
5. Holding onto the edges of the table, carefully flip the table over.



ASSEMBLED ELLAVATE TABLE WITH FIXED LEGS

FOR MISSING PARTS OR QUESTIONS, PLEASE CALL CUSTOMER SERVICE AT 888-705-0777.

