

TOOLS

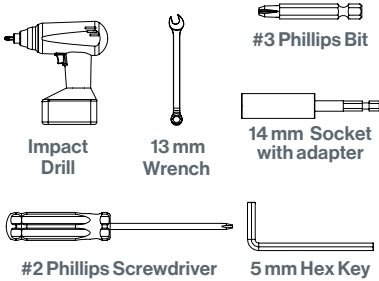

PARTS & HARDWARE LIST

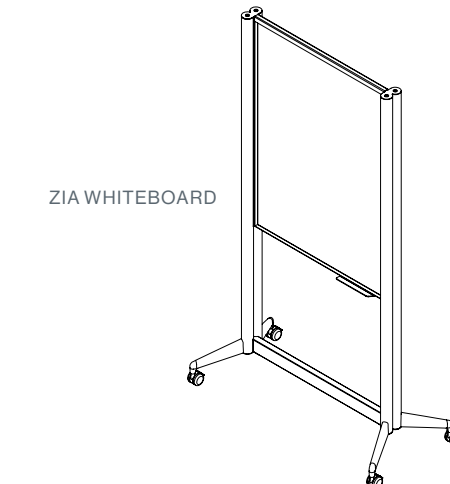
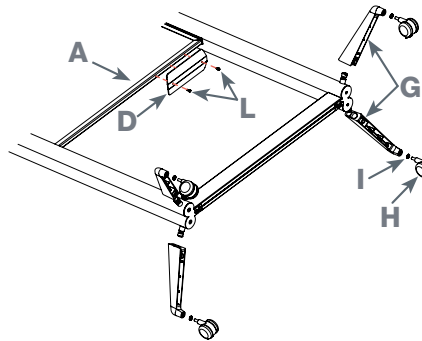
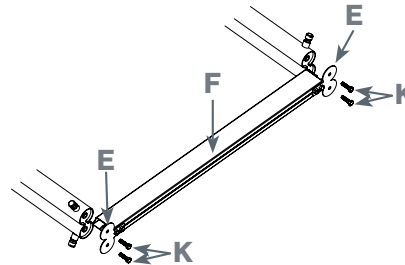
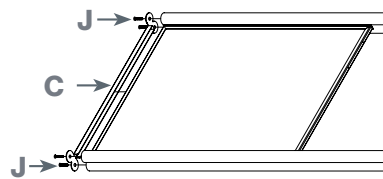
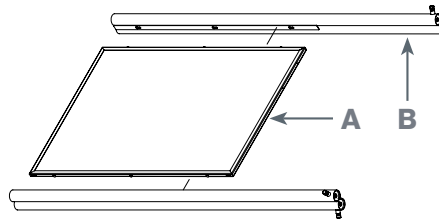
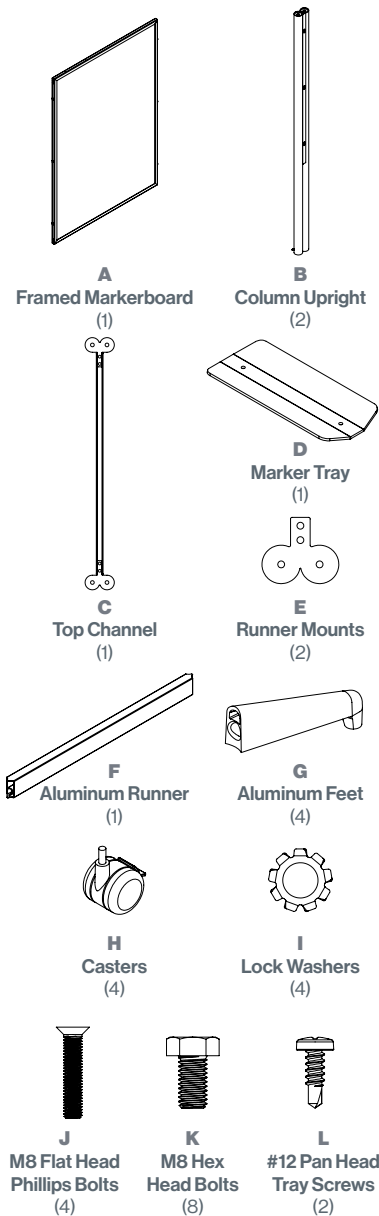

ZIA WHITEBOARD

ASSEMBLY STEPS

1. Lay the Framed Markerboard (A) on a flat, carpeted surface.
2. Align Notched Keyholes on Column Uprights (B) with pegs on Framed Markerboard (A). Slide Column Uprights (B) upward on pegs.
3. Align the Top Channel (C) with the top of the framed Markerboard (A) and column uprights (B).
4. Fasten the Top Channel (C) using (4) M8 Flat Head Phillips Bolts (J).
5. Attach (2) Runner Mounts (E) to the underside of the Aluminum Runner (F) using (4) M8 Hex Head Bolts (K).
6. Align the Aluminum Runner (F) between the bottom of the Column Uprights (B). Fasten using (4) M8 Hex Head Bolts (K).
7. Ensure that all Mounting Pins are secure on Column Uprights (B). If necessary, use a 14mm wrench to tighten.
8. Place (4) Aluminum Feet (G) onto Pins. Tighten (4) Aluminum Feet (G) onto Pins using 5mm Hex Key.
9. Attach (4) Casters (H) to Aluminum Feet (G) using a 13mm wrench.
10. Attach Marker Tray (D) to the underside of Framed Markerboard (A) using (2) #12 Pan Head Tray Screws (L).
11. Bring the Whiteboard to the upright position.

FOR MISSING PARTS OR QUESTIONS, PLEASE CALL CUSTOMER SERVICE AT 888-705-0777.