

### Product Specification

Sketch										Desk thickness	
Item	Monitor size	Weight range (lbs)	Lift	Tilt	Swivel	Pivot	VESA	Packing size (in)	N.W.(lbs)	Grommet	Desk clamp
Specification	≤24"	4.4-22	13 3/8"	+75°~ -45°	±90°	±90°	3**3"	22.8*8.9*6.5	15	2 3/8"	2"
							4**4"				

### Product Size (mm)

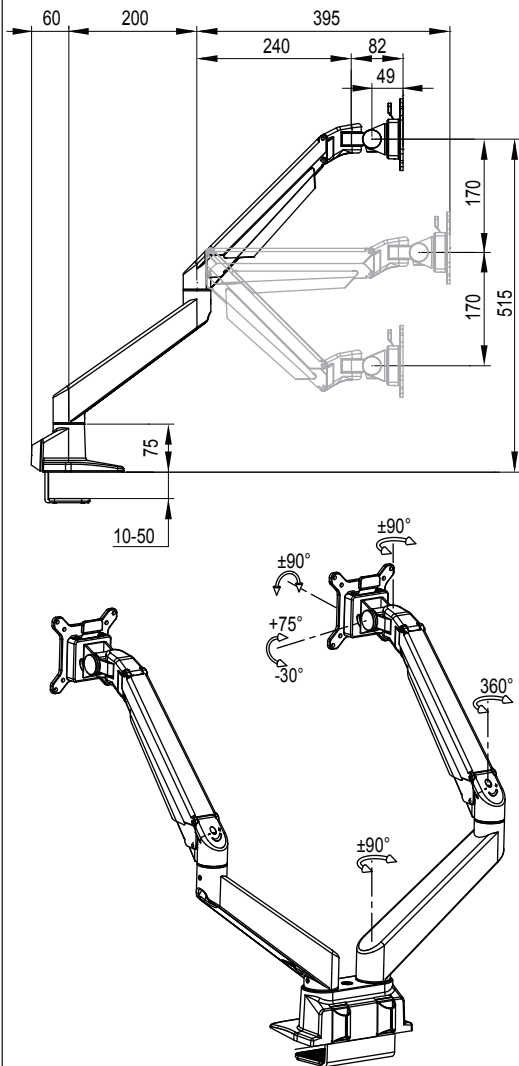

### Installation – Desk Clamp

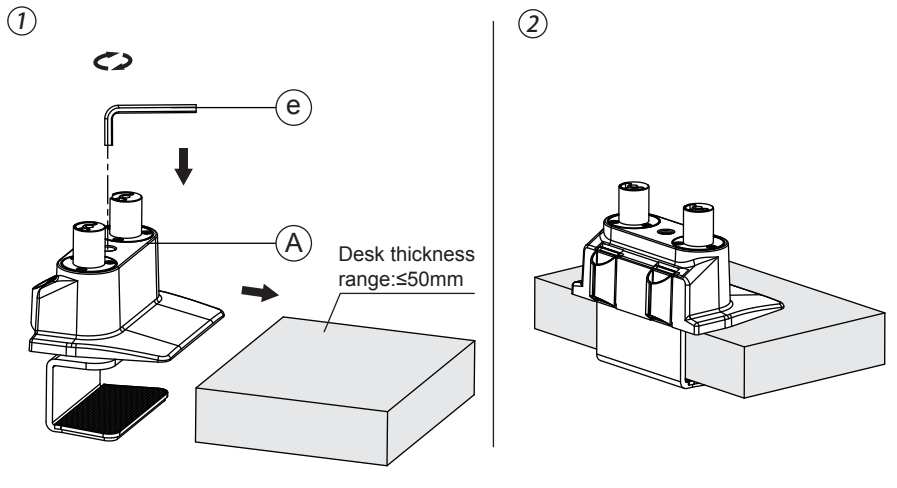

### Installation – Thru-desk

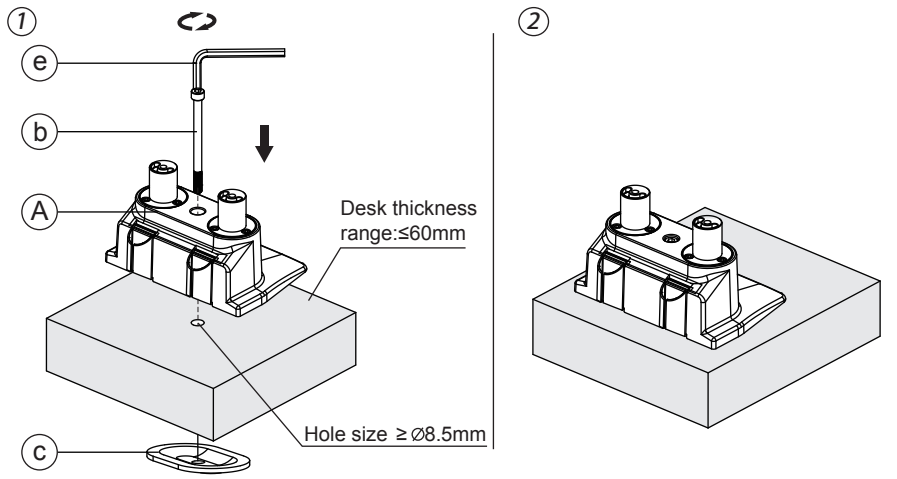

### Install Procedure

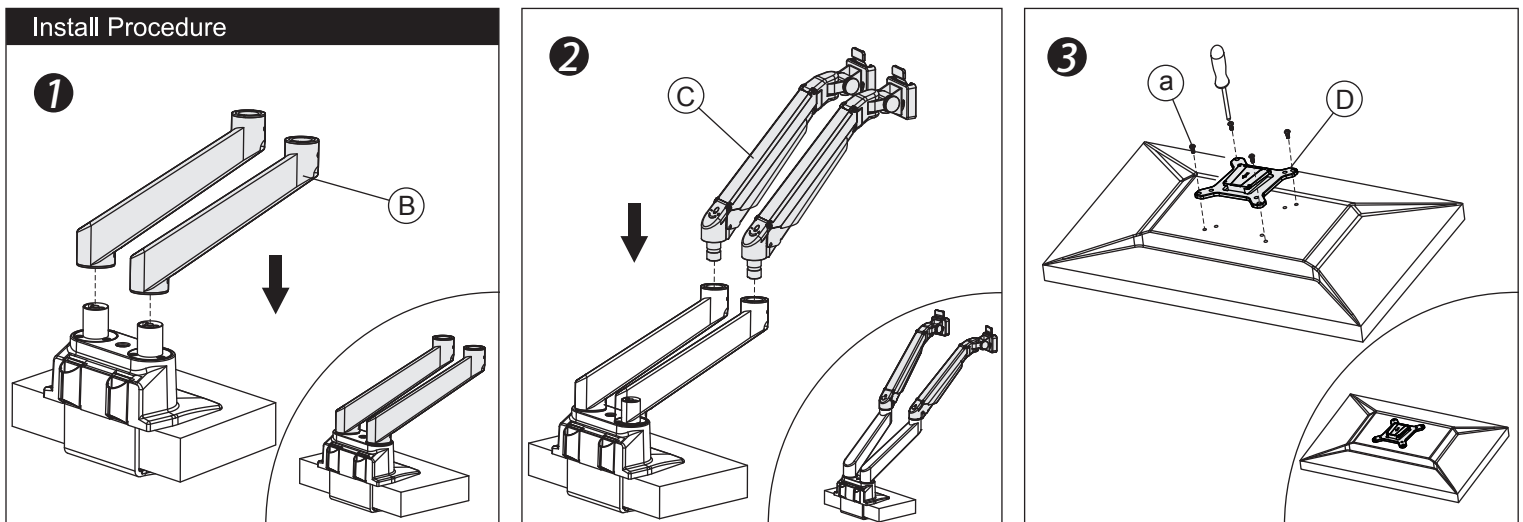

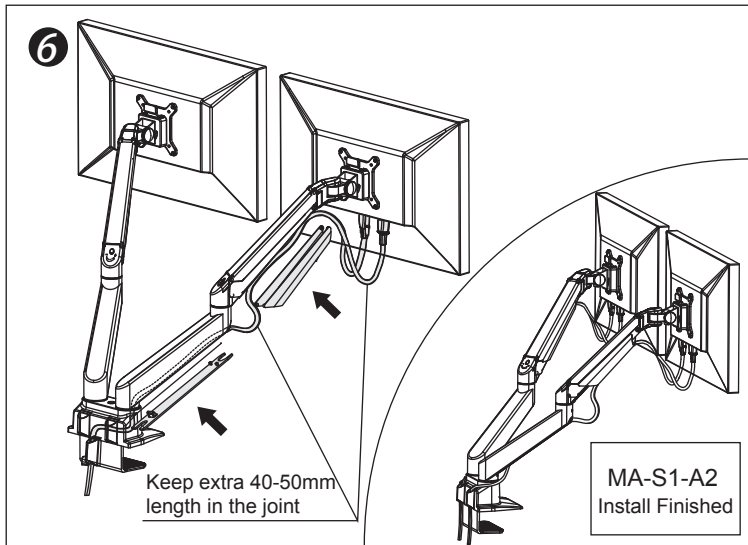
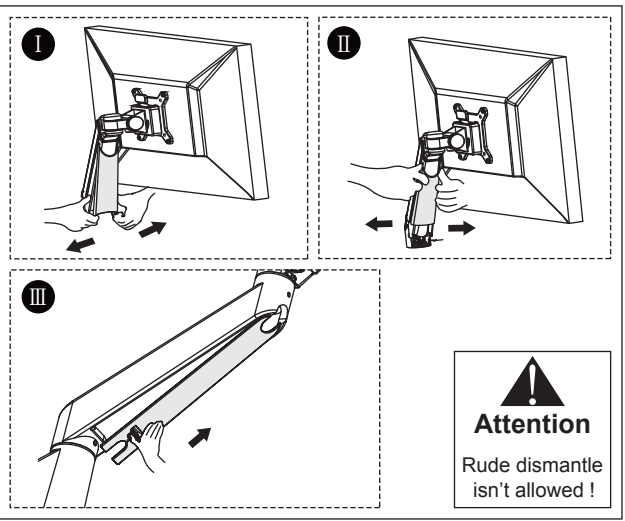
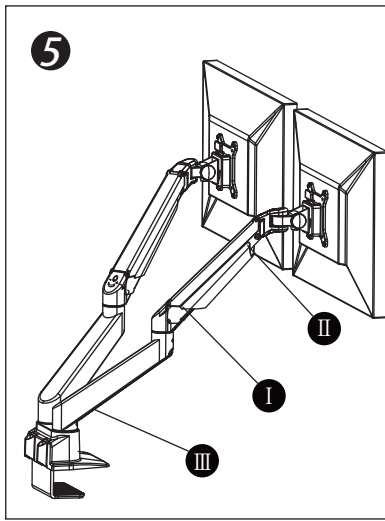
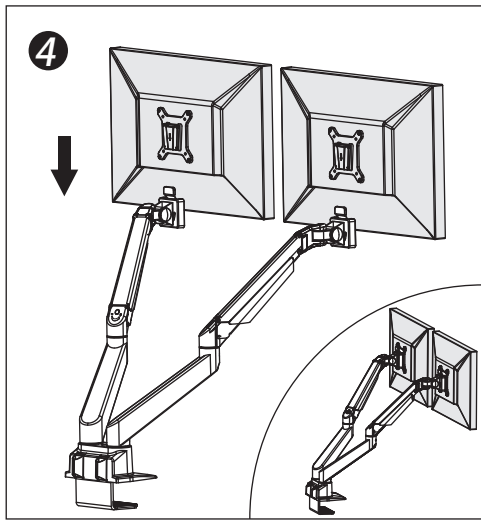

### Adjust Procedure

Adjust this according to monitor weight

Don't adjust this unless the gas arm is horizontal

Monitor remove

Try more to make above adjustment based on monitor weight to get best free-stop effect

Module List			
No.	Sketch	Specs	Quantity
A			1
B			2
C			2
D			2

Part List			
No.	Sketch	Specs	Quantity
a		M4x12	8
b		M8x160	1
c			1
d		M4	1
e		M6	1