

SYM	ECN	DATE	BY	CHANGE
A	-	1/12/12	DS	New Drawing

## ASSEMBLY INSTRUCTIONS

1. Assembly End Bases As Shown On Assembly Drawing ASY 1145.
2. Insert Hex Rod of Handle Assembly Into Each Column Assembly and Fully Retract Columns.
3. Position Top Upside Down On Carpet or Other Non-Abrasive Surface.
4. Determine Desired Handle Location, and Position the Handle Side End Base Onto the Table Top with Wider Side of Mounting Plate Towards Center of Table to and Attach with 8x) #12 x 1" Long Screws Provided.
5. Slide Hex End of Handle Assembly Thru Gearing in Column As Shown Below, Until Handle Assembly Extrusion Touches Mounting Plate. Note: When Handle is Pushed In, The Knob on the Handle Assembly Should Be Close to Flush with Edge of Table Top. Attach Handle Assembly with #12 x 1" Long Screws.
6. Align Handle Back Cover with Hex Rod of Handle Assembly and Slide Cover Up Towards Column Until it Touches the Mounting Plate. Attach to the Table Top With 2x) #12 x 1" Long Screws.
7. Slide One End of Drive Rod Assembly Into Column That Is Attached to the Table Top.
8. Position Unattached Column Assembly Into Place. If Needed, Turn Handle to Align Hex End of Drive Rod with Gearing Of Column. Attach Column With 8x) #12 x 1" Long Screws.

Parts List		
Seq	Qty	Description
1	1	End Base Assembly CW
2	1	End Base Assembly CCW
3	1	Drive Rod Assembly
4	1	Handle Assembly
5	1	Handle Back Cover
6	Varies	Screw, #12 x 1" Long

Standard Location of Handle, Turning Handle Clockwise Extends Column

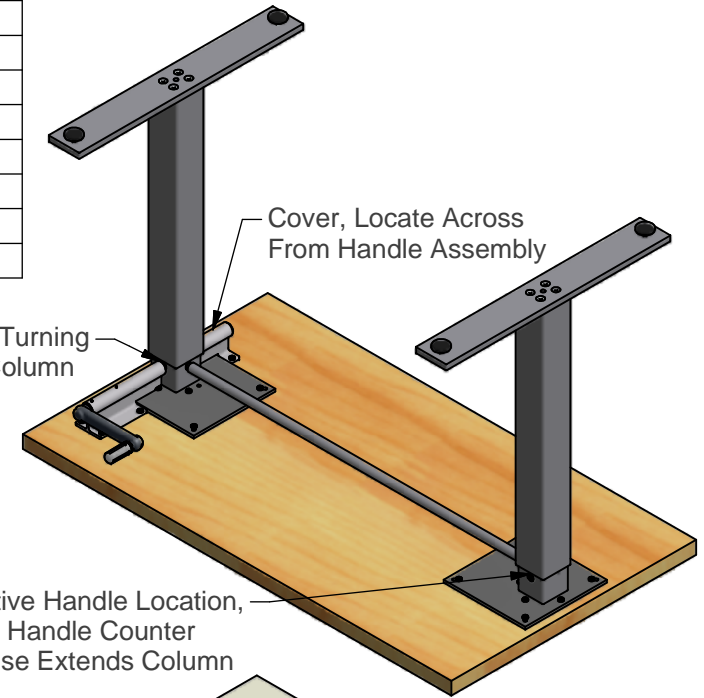

Alternative Handle Location, Turning Handle Counter Clockwise Extends Column

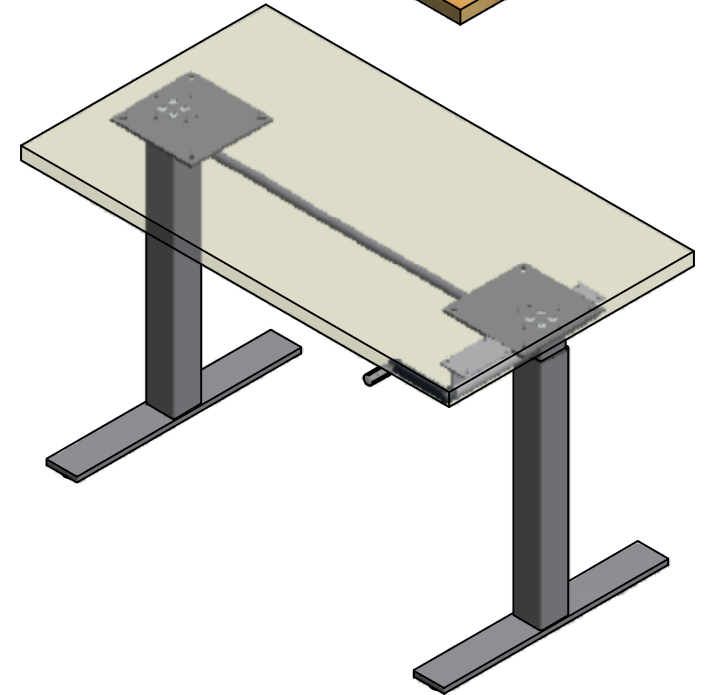
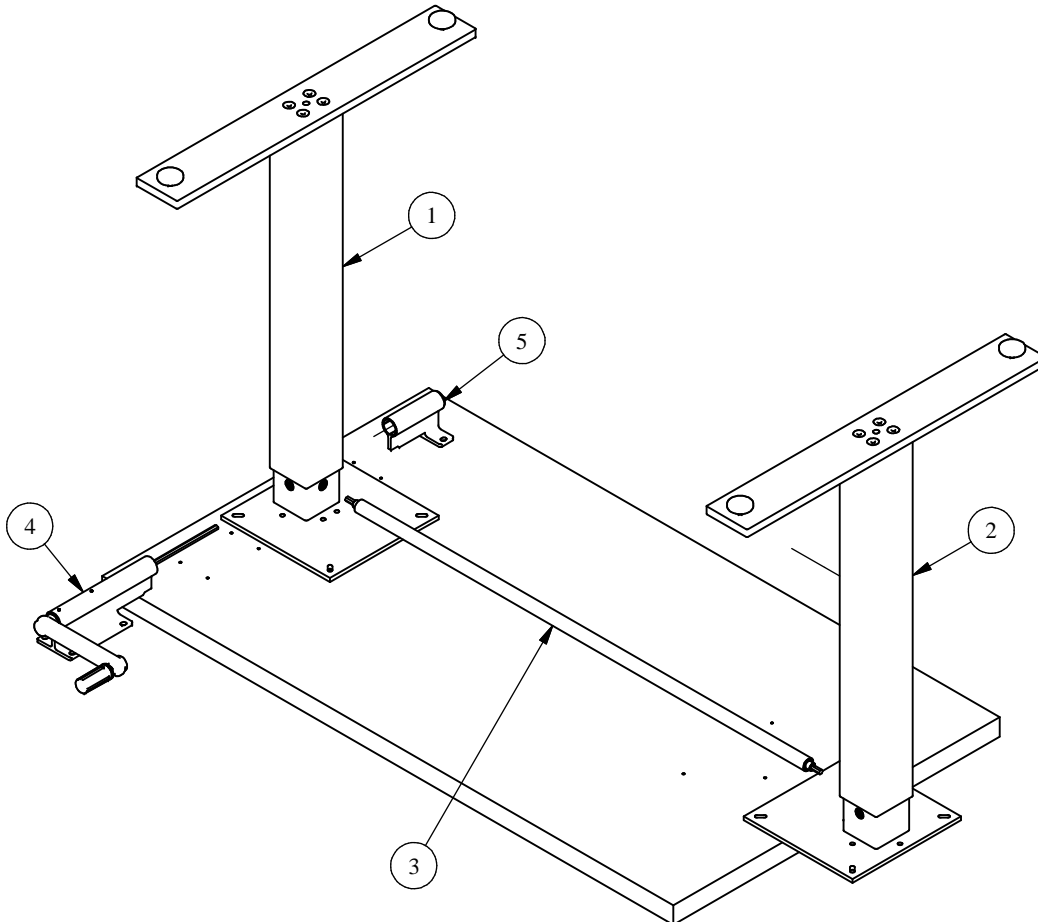

DRAWING#	REVISION
ASY 1144	A
SHEET 1	OF 1