

TOOLS

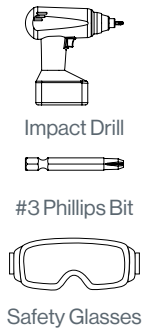

PARTS & HARDWARE LIST

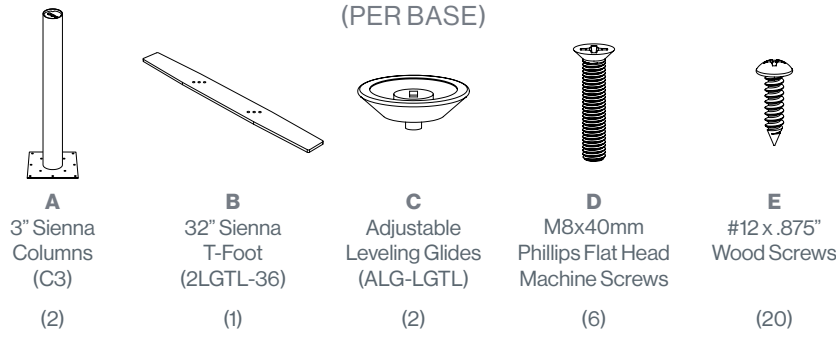

BASE ASSEMBLY

- Stand two Sienna Columns (A) upright with the mounting plate downward.
- Align 3 countersunk holes in the bottom of T-foot (B) with insert plate holes inside the Sienna Column (A).
- Install (3) M8 (D) machine screws into countersunk holes securing T-Foot (B) to column (A). Repeat for the second column.
- Install (2) adjustable leveling glides (C) into outer holes on the bottom of the T-Foot (B).

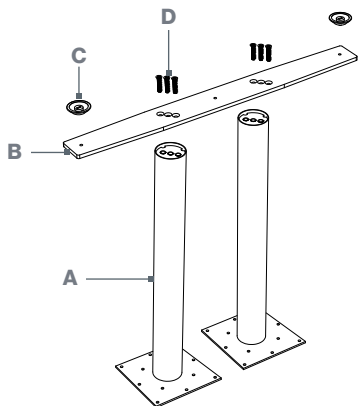
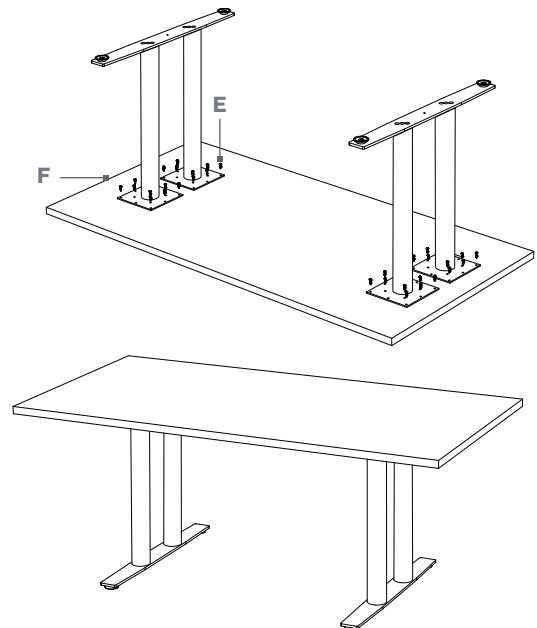

TABLE ASSEMBLY

- Lay the tabletop (F) upside down on a piece of cardboard or carpeted surface.
- Align the base with pre-drilled holes on underside of the table surface.
- Use (20) #12 wood screws (E) to secure base to the tabletop. Repeat for additional base assemblies.
- If a table support bar (G) is provided, attach it with supplied hardware.
- Holding onto the edges of the table, carefully flip the table over.



ASSEMBLED SIENNA 2TL TABLE

FOR MISSING PARTS OR QUESTIONS,
PLEASE CALL CUSTOMER SERVICE AT 888-705-0777.

