

#### TOOLS

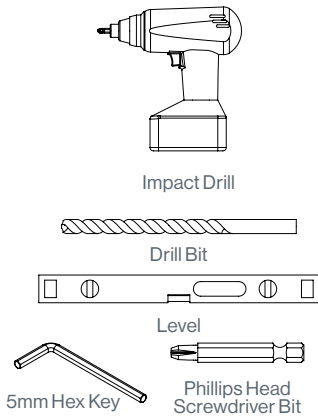

#### PARTS & HARDWARE LIST

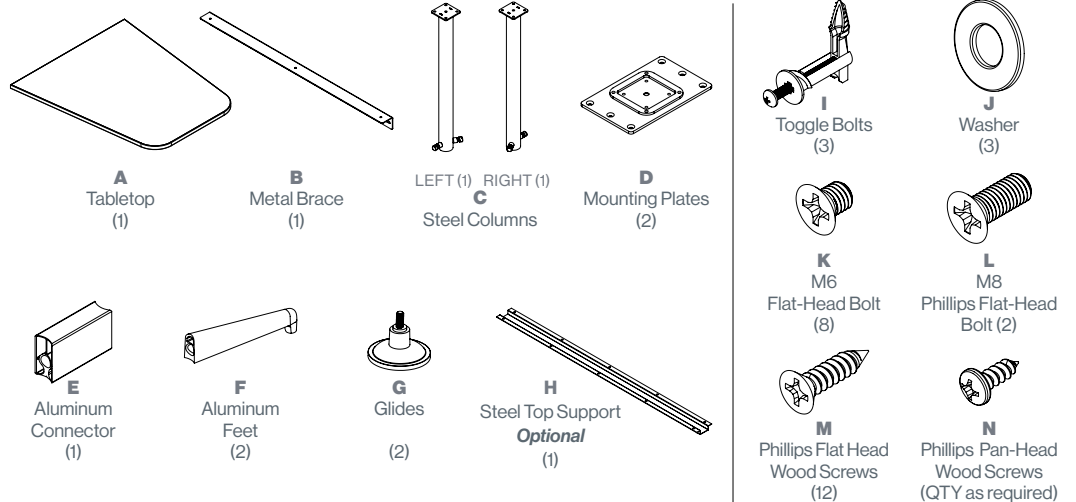

### ASSEMBLY STEPS

**1** Mount the metal brace to the wall at its proper height using the included toggle bolts (3) and washers (3). Ensure the brace is level. See diagram below.

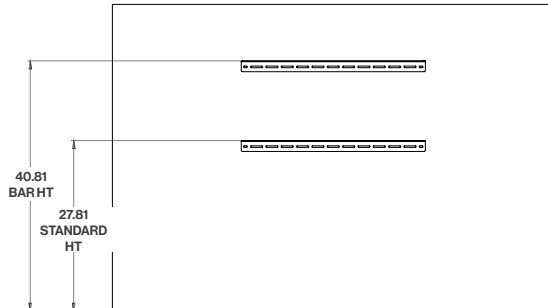

**2** Install (4) M6 flat head bolts through steel columns into mounting plates.

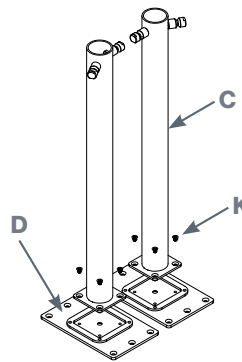

**3-4** Install (1) M8 flat head bolt through mounting plates into steel columns.

Ensure that all mounting pins are securely fastened to the steel columns. If necessary, use a 14 mm wrench to tighten them.

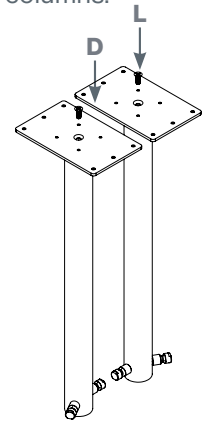

**5-6**

Place the aluminum connector onto the mounting pin between the steel columns.

Tighten the aluminum connector onto the mounting pins using a 5mm Hex Key.

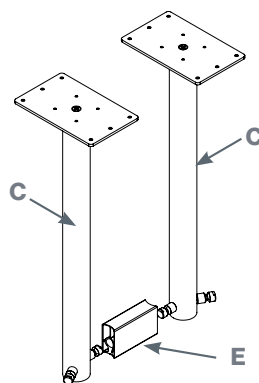

**7**

Attach Column Assembly onto the bottom of the table surface using (12) Phillips wood screws.

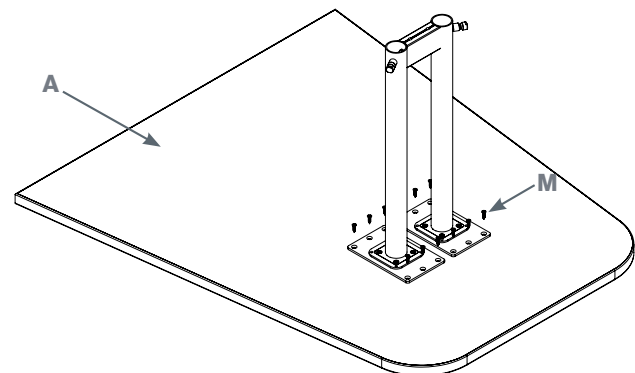

**8-9**

Place (2) aluminum feet onto pins

Tighten (2) aluminum feet onto pins using a 5mm Hex key.

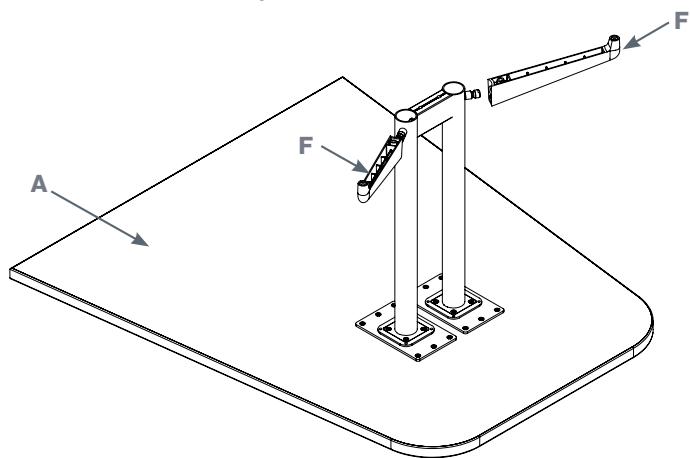

**10**

Attach (2) glides to (2) aluminum feet.

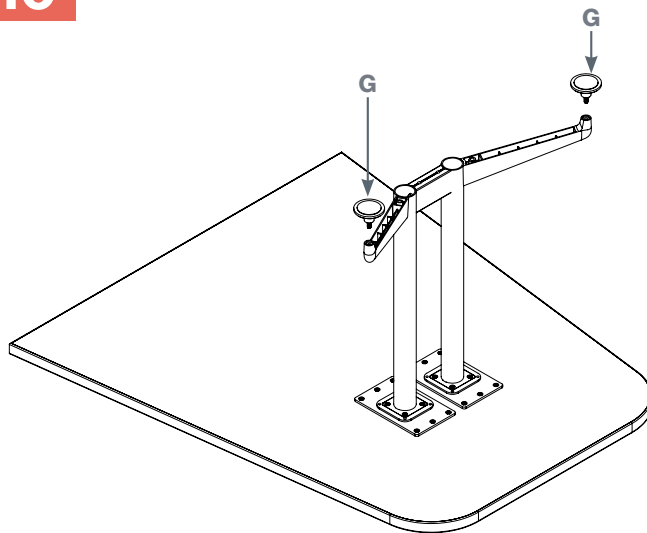

**11**

Flip the table and align it with the metal brace, then secure it with Phillips pan-head wood screws.

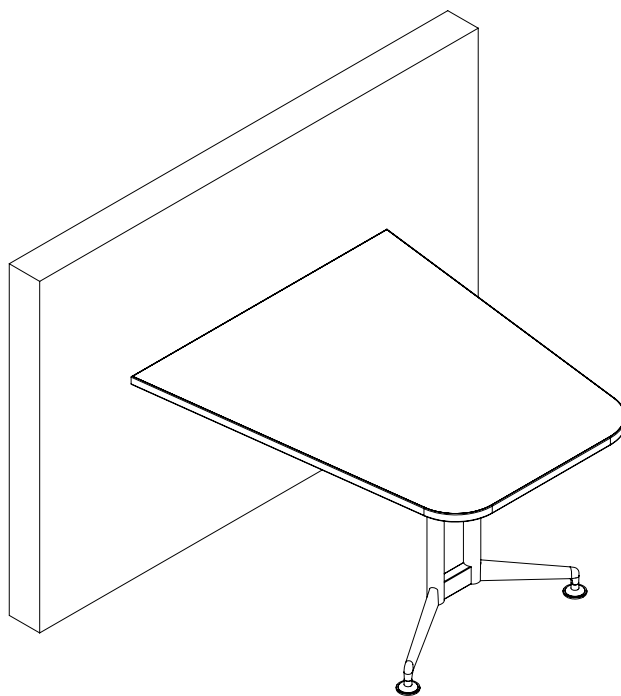
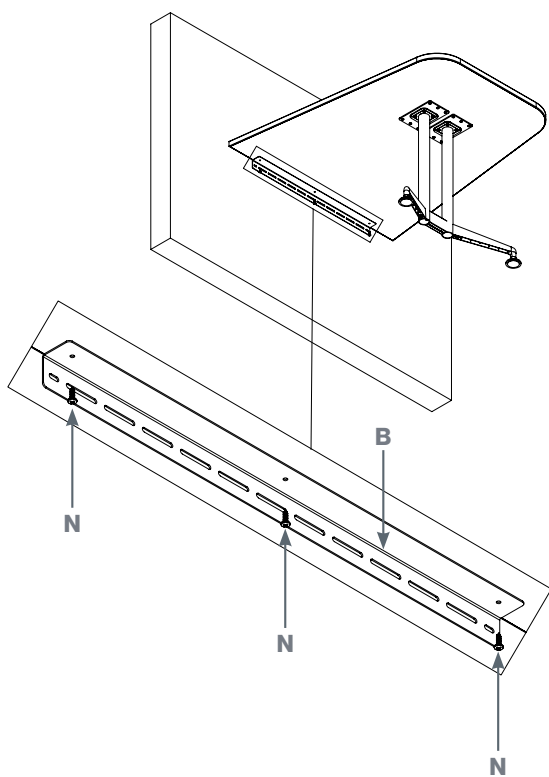

ASSEMBLED ZIA MEDIA TABLE