

TABLE | SHAPES & SIZES



TABLE | HEIGHTS

Designed to maintain nominal table heights independent of glide or caster option.

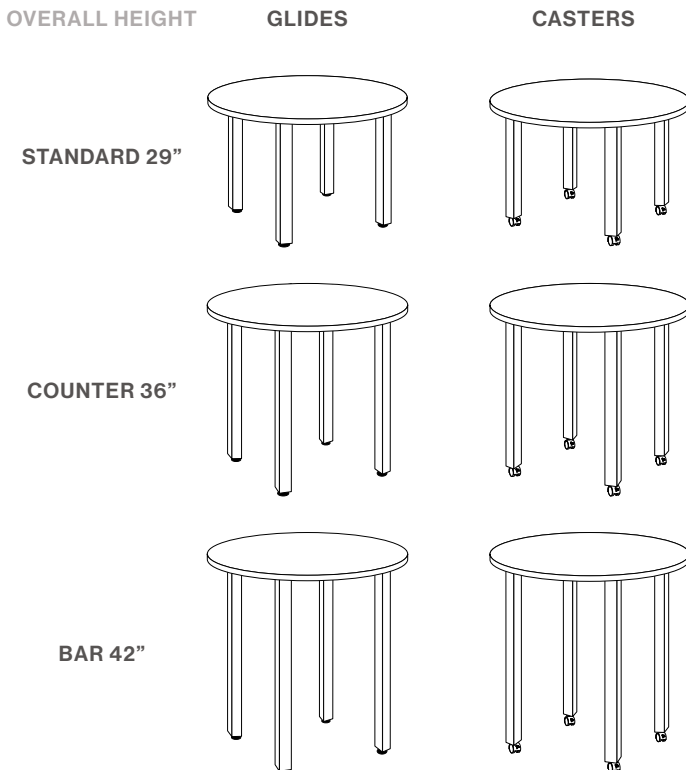

TABLE CONSTRUCTION

- Overall Heights: Dining: 29" Counter: 36" Bar: 42"
- Welded construction
- 2- 3/8" x 2- 3/8" square 14 gauge steel columns
- 5" x 5" x 7/32" corner mounting plate
- 2-3/8" diameter levelers with steel threaded inserts
- Specify Glides or Casters
- Base color: All standard powder coat finishes
- Top: HPL, all standard laminates are available
- Edge: 3mm poly

OPTIONS

- Custom height: 5" - 42"
- Casters
- Table connectors

ACCESSORIES

- Grommets
- Power & Data
- Wire management

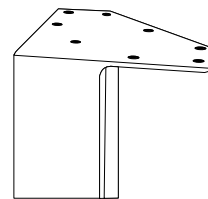

Corner mounting plates allow legs attachment flush with table edges

SQUARE POST LEG | BY TABLE HEIGHT

RECTANGLE	PART NUMBER
29" H	SQ-RH
	SQ-RH-C
36" H	SQ-RH- 36
	SQ-RH- 36-C
42" H	SQ-RH- 42
	SQ-RH- 42-C

-C
for legs featuring Casters