

C-LEG

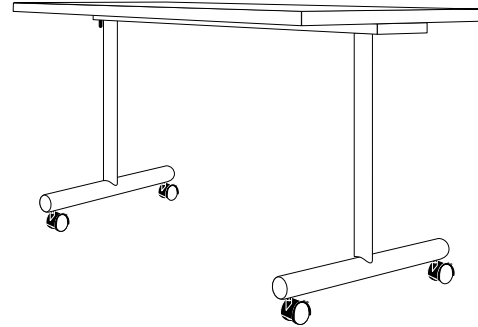

T-LEG



**TABLE | SIZES**

- 18" x 36"      ■ 24" x 36"      ■ 30" x 36"
- 18" x 42"      ■ 24" x 42"      ■ 30" x 42"
- 18" x 48"      ■ 24" x 48"      ■ 30" x 48"
- 18" x 54"      ■ 24" x 54"      ■ 30" x 54"
- 18" x 60"      ■ 24" x 60"      ■ 30" x 60"
- 18" x 66"      ■ 24" x 66"      ■ 30" x 66"
- 18" x 72"      ■ 24" x 72"      ■ 30" x 72"

**TABLE CONSTRUCTION**

- T-Leg or C-Leg
- Height: 29"
- 2" diameter columns, 14 gauge steel
- 2" diameter feet, 14 gauge steel end caps
- Heavy-duty tubular steel mounting beam
- Standard 2" locking casters
- Single point locking mechanism
- Steel hinges
- Tight nesting: 9" between each table and add 2" to the length
- Base color: All standard powder coat finishes
- HPL, all standard laminates are available
- Edge: 3mm poly

**ACCESSORIES**

- Quick Align table connector
- Grommets: round or rectangular
- Power & data
- Wire management