

Kingston C-Leg Flip Table Assembly Instructions

Parts Included:

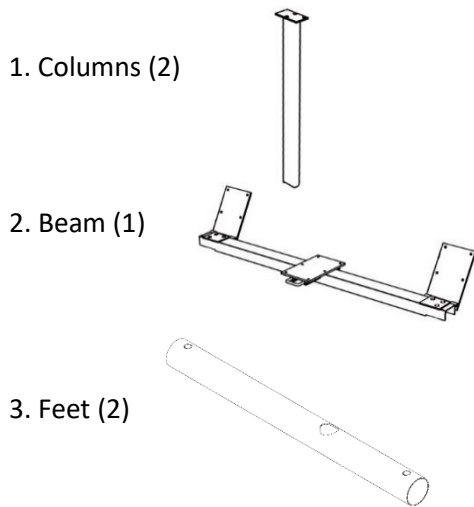

Hardware:

- 1. Small Screws (2)
- 2. Screws (18)
- 3. Hex Bolts (2)
- 4. Washers (2)
- 5. Rubber Bumpers (2)
- 6. Casters (4)

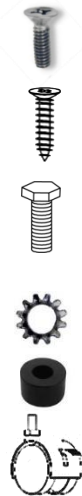

Tools Needed:

- 13mm ratchet or impact drill
- 3/8" socket adapter
- 13mm socket
- 13mm wrench (for casters)
- #3 Phillips bit
- Safety Glasses

If you have any questions or concerns, please call Customer Service at 888.705-0777.

Instructions

Base Assembly

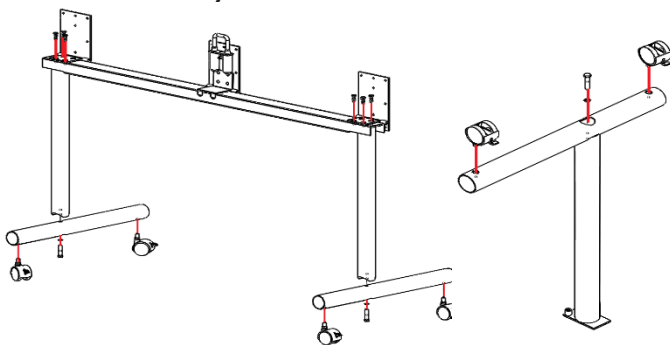

Base Assembly:

1. Assemble legs by setting mounting plate on the floor with the bottom of the column up. Place the foot over the column lining up the holes in the foot and the column. Insert hex head bolt and washer through the foot and into the column. Tighten bolt securely.
2. Thread two caster stems into the base of each foot. Use 13mm wrench to tighten the stems.
3. Slide the legs into the slots on the ends of beam and attach to beam with flat head bolts and washers. Start bolts by hand to prevent cross threading. Tighten the bolts with #3 Phillips bit with a fully charged impact drill.

Table Assembly

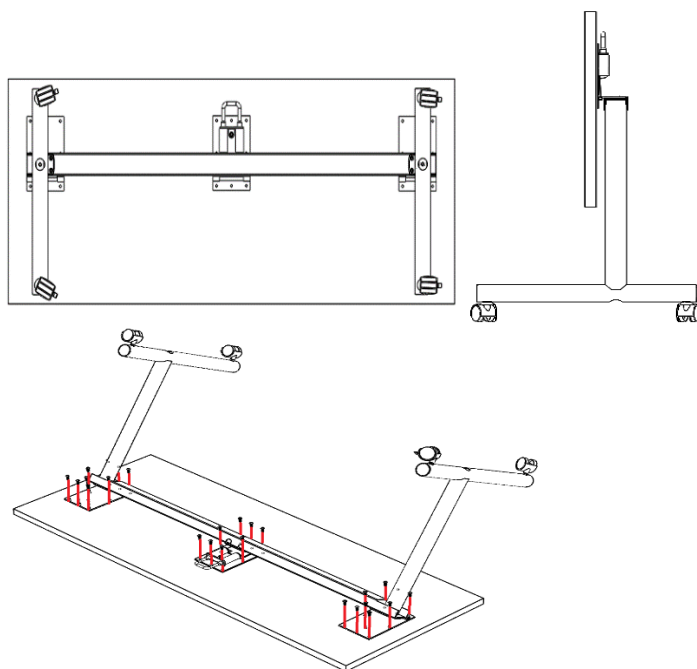

Table Assembly:

1. Lay top on carpeted or cardboard surface with pilot holes facing up.
2. Remove pre-installed support beam from base of table using impact drill with #3 Phillips head bit to remove screws in support beam.
3. Align the holes in the flipping beam with pilot holes in the table top.
4. Ensure the flipping beam is installed so that the flipping handle is facing towards the non-user side of the table as illustrated in the image to the left.
5. Use impact drill with #3 Phillips bit to install wood screws through the base in to table top. **Fully tighten screws.**
6. Holding onto the edges of the top, carefully turn the table over in the upright position. Wipe of the top and the base with a soft clean cloth. Enjoy your table!



START BOLTS BY HAND TO PREVENT CROSS THREADING